

DESIGNER LINE REFRIGERATOR/FREEZER

Model: D3RRFEN

Natural Refrigerant R-290 Model

Designer Line

3-Section Extra-Wide Dual Temp Side-By-Side Reach-In Refrigerator/Freezer (0°F)

D3RRFEN - Stainless steel front, aluminum end panels and interior

D3RRFENSA - Stainless steel exterior, aluminum interior

D3RRFENSS - Stainless steel exterior and interior



Options and Accessories

(upcharge and lead times may apply)

Stainless steel case back	Shallow depth (consult factory)
Additional epoxy coated steel shelves	Hinged glass doors (consult factory)
Chrome or stainless steel shelves	Increased refrigeration systems
Pan slide assemblies	Special electrical req. (consult factory)
Rehinging of doors (consult factory)	Correctional Facility Options
Wine rack (refrigerator section)	• One way security screws
Casters	• Locking hasp (lock not included)
Custom laminates	• Stainless steel mesh cover
Half doors	• Coverless hinges
Pass-thru (consult factory)	

Consult factory for other model configurations, options and accessories.

Project Name:

Model Specified:

Location:

Item No:

Quantity:

AIA #:

SIS #:

Standard Model Features

REFRIGERATION SYSTEM

Separate, self contained, performance rated "plug" refrigeration systems

Natural, environmentally safe, high efficiency R-290 refrigerant¹

Refrigeration system is readily accessible on top of cabinet, separate from the "food zone"

Automatic, hot gas condensate evaporator

Expansion valve system

CABINET ARCHITECTURE

3" non-CFC polyurethane foam insulation

Smooth, polished chrome workflow door handles

Cam action, lift off hinges

Self-closing doors

Magnetic snap in Santoprene™ door gaskets

Cylinder lock in each door

Heavy duty, epoxy coated steel shelves

Heavy duty pilaster strips

6" adjustable stainless steel legs

MODEL FEATURES

LED interior lighting

Electronic controllers with digital display & hi-low alarm

Top and side air distribution ducts

Cabinet upper side panels and refrigeration "plug" system can be removed and reinstalled at job site

Off-cycle defrost (refrigerator section)

Automatic electric defrost (freezer section)

APPROVAL:

Continental
Refrigerator

Toll-Free: 800-523-7138

Phone: 215-244-1400

Fax: 215-244-9579

539 Dunksferry Road

Bensalem, PA 19020

www.continentalrefrigerator.com

Model Specifications

DIMENSIONAL DATA

Net Capacity (cubic feet)	50/21 (1416/595 cu l)
Width, Overall (inches)	85 1/2 (2172 mm)
Depth, Overall (inches) (including handles)	35 3/8 (899 mm)
Depth (inches) (less doors)	32 (813 mm)
Depth (inches) (doors open 90°)	58 (1473 mm)
Clear Door Width (inches)	21 7/8 (556 mm)
Clear Half Door Height (inches)	27 1/2 (699 mm)
Height, Overall (inches) (including 5" casters)	82 1/4 (2089 mm)
Number of Doors	3
Number of Shelves	9
Shelf Area (square feet) (per section)	20.4 (1.9 sq m)
Tray Slide Capacity (per half section)	11

REFRIGERANT DATA

Condensing Unit Size (H.P.)	1/3 +, 1/2
Capacity (BTU per hour)*	2560, 1590

ELECTRICAL DATA

Voltage (International)	115/60/1 (220/50/1)
Feed Wires (including ground)	3 / 3
Total Amps (International)	6.3 (4.3) / 6.5 (4.1)
Defrost Amps (International)	4.3 (2.2)
(2) 10 ft. Cord/Plug [attach.] (International)	Yes (No)

SHIPPING DATA

Height - Crated (inches)	85 1/2 (2172 mm)
Width - Crated (inches)	90 (2286 mm)
Depth - Crated (inches)	42 (1067 mm)
Volume - Crated (cubic feet)	181 (5125 cu l)
Weight Std - Crated (pounds)	885 (401 kg)
Weight SS - Crated (pounds)	995 (451 kg)

* Rating @ +25°F evaporator, 90°F ambient (refrigerator)

* Rating @ -15°F evaporator, 90°F ambient (freezer)

Figures in parentheses reflect metric equivalents rounded to the nearest whole unit.



Equipped with two NEMA-5-15P Plugs
(varies by country)

Model Plan Views

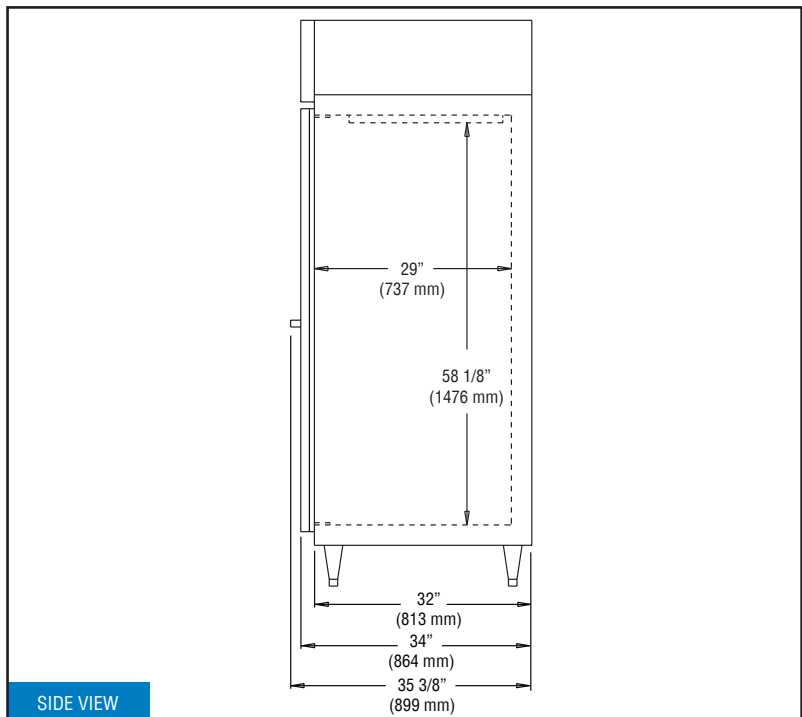
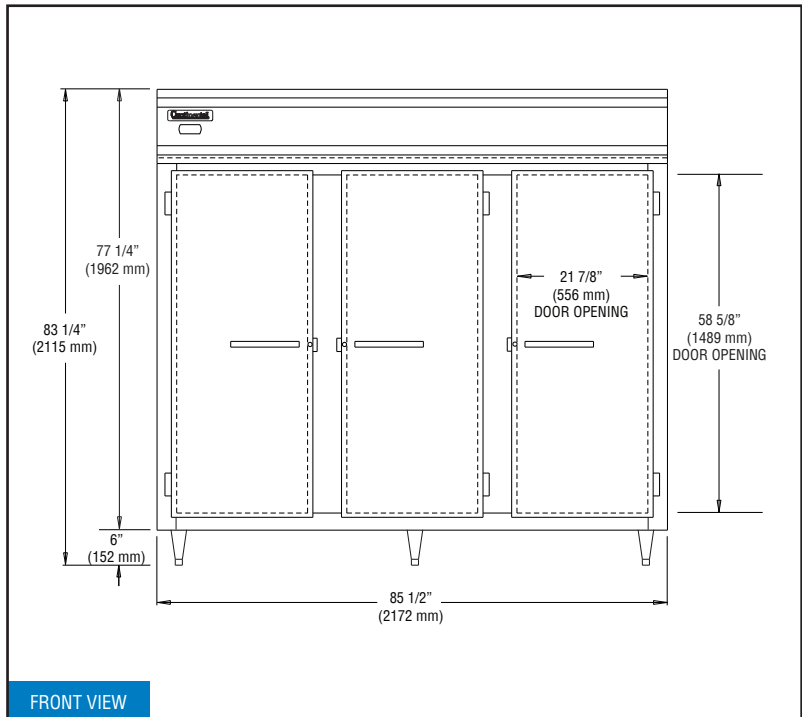

IMPORTANT NOTE: If the cabinet is located directly against a wall and/or under a low ceiling, a minimum clearance of 12" is required on top and 3" on sides and rear.

Continental
Refrigerator

Toll-Free: 800-523-7138
Phone: 215-244-1400
Fax: 215-244-9579

539 Dunksferry Road
Bensalem, PA 19020
www.continentalrefrigerator.com

Due to our continued efforts in developing innovative products, specifications subject to change without notice.

